

METRISO PRIME+

Digital High-Voltage Insulation Test Instrument

3-349-822-03
7/2.22



Test instrument may only be operated under the supervision of a qualified electrician!

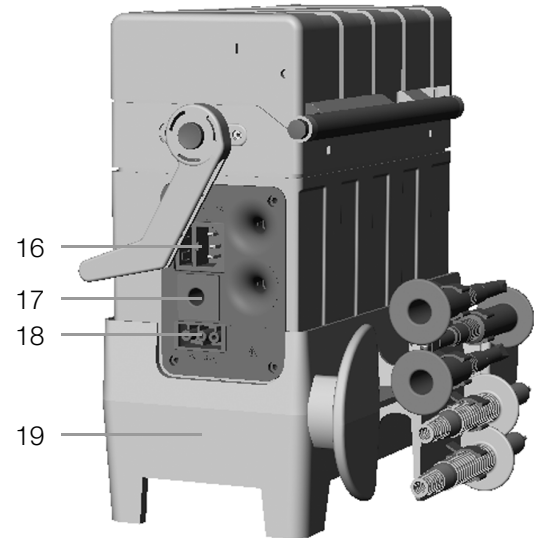

1 Function selector switch

Switch positions:

SETUP: General device settings



Print out measured values and reports



Select data memory function

OFF: Switches the test instrument off *

TEST: Select measuring and test parameters,
and execute measurements and tests

2 : Select main menus and submenus, and adjust values

3 : Select main menus and submenus, and adjust values

4 Socket connector for RS 232 interface

5 LCD panel

6 Signal lamp for test passed (green) / test failed (red)

7 **MENU:** Key for selecting and querying menus for setting parameters, for returning to the main menu and for stopping the measuring process

8 **i/STORE:** Before performing a measurement:
Key for querying context sensitive help
After performing a measurement:
Key for saving measured values and parameters to memory

9 **START:** Key for starting the selected test

10 Signal lamp: "testing ..." (yellow)

11 Pushbuttons (left and right) for releasing the handle

12 Pushbuttons (left and right) for releasing the cover

13 Cover

14 SECUTEST PSI printer module

15 Handle and bar function as a tilt stand

16 Inlet plug for supply power with fuse compartment

17 Connector jack for guard cable (feature G1)

18 Connection for automotive charging adapter J1

19 Device base

Outside: With uptake for measurement cable, test probes and alligator clips

Inside: Uptake for guard cable with test probe (feature G1),
battery compartment



Attention!

Connect 5 m long Leadex 5000 accessory extension cable (feature H1) to + measurement cable only!



Note

Maximum rated voltage to earth is 1000 V~, even if permanently connected measurement cables for 2 kV~ CAT II are permissible.

* During battery operation: battery is disconnected
During mains operation: transformer is still connected to the mains

Contents	Page	Contents	Page
1 Applications	7	4.3 Breakdown Voltage	28
1.1 List of Available Features	8	4.3.1 Setting Test Parameters	29
2 Safety Features and Precautions	9	4.3.2 Starting the Test	29
2.1 Checklist for High-Voltage Tests	10	4.4 Capacitance Measurement and Determination of Dielectric Discharge (optional)	30
2.2 Significance of Symbols	11	4.4.1 Setting Test Parameters	30
2.2.1 Symbols on the Device	11	4.4.2 Starting the Test	31
2.2.2 Symbols in the Operating Instructions	11	4.5 Voltage Measurement (protection against residual voltage)	32
2.2.3 Symbols in the User Interface	11	4.5.1 Setting Test Parameters	33
3 Initial Start-Up	12	4.5.2 Starting the Test	33
3.1 Battery Operation, Feature C1	12	5 Processing, Reorganizing and Deleting Data	34
3.1.1 Removing the Device Base and Inserting or Replacing the Battery Pack	12	5.1 Select Device under Test (DUT)	34
3.2 Mains Connection	14	5.1.1 Entering Descriptions	35
3.3 User Interface	15	5.1.2 Copying Descriptions	36
3.4 Help Functions	15	5.1.3 Deleting Descriptions	36
3.5 Setup	16	5.2 Processing Data (checking measured values)	36
3.5.1 Adjusting Contrast and LCD Illumination	17	5.3 Data Reorganization	37
3.5.2 Setting Date and Time	17	5.3.1 Deleting Already Printed Data	37
3.5.3 Beeper Settings	18	5.3.2 Memory Test	37
3.5.4 Executing the Self-Test	19	5.4 Clearing the Memory	38
3.5.5 Organizing Report Data with ETC	20	6 Printing Test Results	39
4 Performing Tests	21	7 Characteristic Values	40
4.1 Insulation (resistance) Test	21	8 Data Interfaces	43
4.1.1 Setting Test Parameters	22	8.1 RS 232 Serial Interface	43
4.1.2 Starting the Test (U_{NOM} , U_{VAR})	23	8.1.1 Software Analysis of Measurement Results	43
4.1.3 Starting the Test (U_{STEP})	23	8.1.2 Interface Specification and Protocol	43
4.1.4 Data logger function (min log)(as of firmware version AH)	24	8.1.3 Connector Pin Assignments	43
4.1.5 Measurements with the Guard Cable (feature G1)	25	9 Displays and Error Messages – Causes – Remedies	44
4.2 Polarization Index Measurement	26		
4.2.1 Setting Test Parameters	27		
4.2.2 Starting the Test	27		

10	Maintenance	46
10.1	Replacing the Mains Fuse	46
10.2	Testing of Rechargeable Batteries	46
10.3	Housing and Test Probes	46
10.4	Measurement Cables	47
10.5	Recalibration	47
10.6	Device Return and Environmentally Compatible Disposal	47
11	Appendix	48
11.1	Glossary	48
11.2	Minimum Display Values in Consideration of Measuring Error	48
11.3	Voltage at Device Under Test During Insulation Resistance Test	49
11.4	Index	50
12	Repair and Replacement Parts Service, Calibration Center* and Rental Instrument Service	51
13	Product Support	52

1 Applications

The METRISO PRIME+ insulation measuring instrument is in compliance with the following standards and regulations:

Standard	DIN EN 61557-1:2007 DIN EN 61557-2:2008
VDE regulation	VDE 0413-1:2007 VDE 0413-2:2008

“Equipment for testing, measuring or monitoring protective measures in systems with line voltages of up to 1000 V AC and 1500 V DC, part 2, insulation resistance measuring instruments”.

The instrument is suitable for the measurement of insulation resistance at voltage-free devices and equipment with nominal voltages of up to 1000 V. It is also suitable for the measurement of insulation resistance with values of up to 1 T Ω , and open-circuit voltages of up to 5000 V.

The instrument is also equipped with a 1000 V measuring range for direct and alternating voltages. This provides users with the advantage of checking devices under test for the absence of voltage, and discharging capacitive devices under test.

All of the values required for approval reports can be measured with this instrument.

The SECUTEST PSI module (feature I1) – a printer which can be inserted into the cover which includes an integrated interface and keypad – expands the range of possible applications for the METRISO PRIME+.

All measured data can be archived with the help of measurement and test reports which can be printed out directly via a PC. This is a very important feature, especially with regard to product reliability.

Using the test probes (Electrical Safety)

Maximum rated voltage	300 V	600 V	1000 V	5000 V
Measuring category	CAT IV	CAT III	CAT II	—
With safety cap attached	•	•	—	—
Without safety cap	—	—	•	•



Attention!

Measurements per DIN EN 61010-031 may only be performed in environments in accordance with measuring categories III and IV with the safety cap attached to the test probe at the end of the measurement cable.

In order to establish contact inside 4 mm jacks, the safety caps have to be removed by prying open the snap fastener with a pointed object (e.g. the other test probe).

Notes Regarding SECUTEST PSI Operating Instructions

In combination with the METRISO PRIME+, the SECUTEST PSI printer module is only used for printing out measured values and for entering comments with the alphanumeric keypad.

The following chapters from the SECUTEST PSI operating instructions are relevant as regards operation together with the METRISO PRIME+:

- Chapter 2 Safety Features and Precautions
- Chap. 3.1 and 3.2 Installing the Batteries and the PSI Module
- Chapter 12 Characteristic Values
- Chapter 13 Maintenance
- Chapter 14 Repair and Replacement Parts Service

The following functions are **not active**, or only make sense in combination with a SECUTEST ... test instrument:

- Display, print and store reports to memory
- Statistics
- Operation with a barcode scanner

1.1 List of Available Features

Features		0	01	02	04	05	07	10	15	43
Country version (user interface language, mains plug type)	A		D	GB international	FRA F	NLD NL	ESP E	ITA I	CHE CH	USA USA
Set of batteries	C	none	with							
“Guard 5000A” measurement cable	G	none	with							
“LEADEX 5000” extension cable	H	none	with							
SECUTEST PSI printer module	I	none	with							

Specify the designation of the basic M5000 instrument in your order, as well as any features which deviate from feature 0!

Example of a complete type designation
(= article number, = order code) for a METRISO PRIME+:

- Test instrument for German speaking countries with DAkkS calibration certificate³⁾ and SECUTEST PSI printer module:
M5000 A01 I1

³⁾ The test instrument can be recalibrated by our calibration service at any time. We recommend a calibration interval of 1 to 2 years.

2 Safety Features and Precautions

The METRISO PRIME+ test instrument have been manufactured and tested in accordance with the following safety regulations:

Standard	DIN EN 61557-1:2007 DIN EN 61557-2:2008 IEC 61010-1:2010 DIN EN 61010-1:2011
VDE regulation	VDE 0413-1:2007 VDE 0413-2:2008 VDE 0411-1:2011

If used for its intended purpose, safety of the user, the instrument and the device under test is assured.

Read the operating instructions completely and carefully before using the device, and follow all instructions included therein.

The operating instructions should be made available to all users.

Observe the following safety precautions:

- The instrument may only be connected to a 230 V or 120 V electrical system (depending on the country-specific design) which is protected with a fuse or circuit breaker with a maximum nominal current rating of 16 A.
- Be prepared for the occurrence of unexpected voltages at devices under test (for example, capacitors may be dangerously charged).
- Make sure that connector, measurement and test cables are not damaged (i.e. broken insulation, kinks, interruptions etc.).
- Impulse withstand voltage of up to 2.5 kV may occur in measurement category II systems with 230/400 V.
- If only the batteries are to be charged (instrument is ready for operation in SETUP position), please ensure that the test instrument cannot be used by unauthorized personnel during the charging process.

- Measurement may only be performed on voltage-free equipment and devices.
- Measurements may not be performed under moist ambient conditions, where condensation has occurred, or in explosive atmospheres.
- Do not disconnect the measurement cables until the device under test has been fully discharged.
- Observe accident prevention regulation (Health and Safety Policy DGUV regulation 3), "Electrical Systems and Equipment".
- Do not perform measurements alone: always have a second person help if possible.
- Make sure that measurement cables are connected correctly.
- Do not touch the test probes at any point beyond the finger guard.

The METRISO PRIME+ may not be used:

- If visible damage is apparent
- With damaged connector, measuring or test cables (test cables may not, under any circumstances, be mechanically damaged or kinked, because impaired insulation characteristics may otherwise result)
- If these no longer function flawlessly

In such cases, the devices must be removed from service and secured against any possible inadvertent use. Send the instrument to our Repair and Replacement Parts service department in such cases (see chapter 12 on page 51).

Opening of Equipment / Repair

The equipment may be opened only by authorized service personnel to ensure the safe and correct operation of the equipment and to keep the warranty valid. Even original spare parts may be installed only by authorized service personnel.

In case the equipment was opened by unauthorized personnel, no warranty regarding personal safety, measurement accuracy, conformity with applicable safety measures or any consequential damage is granted by the manufacturer.

2.1 Checklist for High-Voltage Tests



Attention!

Measurements may not be performed under moist ambient conditions, where condensation has occurred or in explosive atmospheres.

Personnel Safety

- ⇒ Turn the machine under test off and lock it in the off position.
- ⇒ Perform insulation resistance measurement.
- ⇒ Make sure that the system is grounded.
- ⇒ Secure the danger zone with barriers, closing even narrow entrance ways.
- ⇒ Set up warning signs such that they are plainly visible.
- ⇒ Set up warning lamps such that they are plainly visible.
- ⇒ Attach the emergency stop button in a plainly visible fashion.
- ⇒ Warn personnel working in the area of possible danger.
- ⇒ Always turn the test instrument off with the key switch and remove the key before leaving the work area.

Safety Precautions for the Machine Under Test (recommended)

- ⇒ Review the circuit diagrams and make a note of all electrical circuits.
- ⇒ Disconnect the neutral conductor from the mains.
- ⇒ Short circuit each electrical circuit to itself.
- ⇒ Disconnect control circuits with overvoltage arresters, if the arresters would be triggered by utilized test voltage.
- ⇒ Disconnect PELV circuits (no high-voltage testing is required for these circuits).
- ⇒ Test insulation at each circuit with 1000 V.
(If insulation resistance is OK at 1000 V, no failures should occur during the high-voltage test.)
- ⇒ Disconnect frequency converters.
- ⇒ **Caution in TN systems!**
The protective conductor is connected to the neutral conductor in the junction box. High-voltage is thus applied between the phase conductors and the neutral conductor.
The neutral conductor must be cut if necessary, because it is not disconnected from the mains by means of fuses.

Setting Up the Test Instrument

High-Voltage Test

- ⇒ Test all circuits (conductors) against the protective conductor (all switches in the mains circuit must be turned on, and testing must be performed upstream and downstream from all relays and contactors).
- ⇒ Remove all shorting devices after testing has been completed.

Testing Without Short-Circuiting

- ⇒ Separately test all conductors from all circuits against the protective conductor (the machine could be damaged in the case of arc-over).

Functions Test

- ⇒ The machine must be tested for correct functioning after the high-voltage test, especially as regards safety functions.

2.2 Significance of Symbols

2.2.1 Symbols on the Device

The symbols on the device have the following meanings:



Indicates EC conformity



Life endangering for the operator if the wiring diagram and the operating instructions are not observed!



Warning concerning a source of danger (attention: observe documentation!)



This device may not be disposed of with the trash. Further information regarding the WEEE mark can be accessed on the Internet at www.gossenmetrawatt.com by entering the search term 'WEEE'.



Report functions



Data management

2.2.2 Symbols in the Operating Instructions



Life endangering for the operator if instructions identified with this symbol are not observed



Danger for the operator and the device if instructions identified with this symbol are not observed

2.2.3 Symbols in the User Interface



High-voltage warning,
Voltage at the test probe between 1000 and 5000 V



Warning concerning a source of danger,
Voltage at the test probe between 25 and 1000 V



Insulation measurement:
interference voltage at the test probes

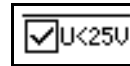

All-clear after an insulation test:
voltage at test probes less than 25 V



Timer function: symbolizes test duration



This symbol appears after the voltage measurement value has been frozen (see chapter 4.5 on page 32).



Indicates progress of the test.



Indicates storage of the measurement value.

3 Initial Start-Up

The METRISO PRIME+ test instrument is supplied with a base which serves as a compartment for storing test cables, the guard cable (feature G1), the test probes and the battery pack (feature C1).



Attention!

The test instrument may only be operated if the base is properly attached and secured.

3.1 Battery Operation, Feature C1

The battery pack is required for operation of the METRISO PRIME+ without mains power. The battery back includes 8 NiMH batteries. No other battery packs may be used.

The battery pack is charged automatically by the integrated mains power pack. Optional use of an automotive charging adapter is also possible. The device must be switched on in this case (any switch position other than OFF).



Attention!

If only the batteries are to be charged (instrument is ready for operation in SETUP position), please ensure that the test instrument cannot be used by unauthorized personnel during the charging process.

3.1.1 Removing the Device Base and Inserting or Replacing the Battery Pack

Please observe instructions included in this chapter if the device is to be retrofitted with a battery pack, or if the battery pack requires replacement.



Attention!

Before dismantling the device base:

- Disconnect the device from the measuring circuit at all poles.
 - Disconnect the device from mains power.
 - Turn the device off (set the switch to OFF).
-

- ⇒ Close the cover and position the handle at the side of the device.
- ⇒ Turn the device upside down, i.e. place it onto its cover.
- ⇒ Unwind the test cables from the cable uptake at the side.
- ⇒ Remove the guard cable from the device base if one is included (feature G1).
- ⇒ Loosen the three Phillips head screws at the bottom of the device base.
- ⇒ Lift the device base up, and set it down at the side of the device with the feet at the bottom.
- ⇒ Place the battery pack onto the two rubber cushions in the recess in the device base such that the connector cable with plug connector from the battery pack is on the same side as the device's connector cable with socket connector. Double-check: The opening at the side of the base coincides with the device's connection panel.

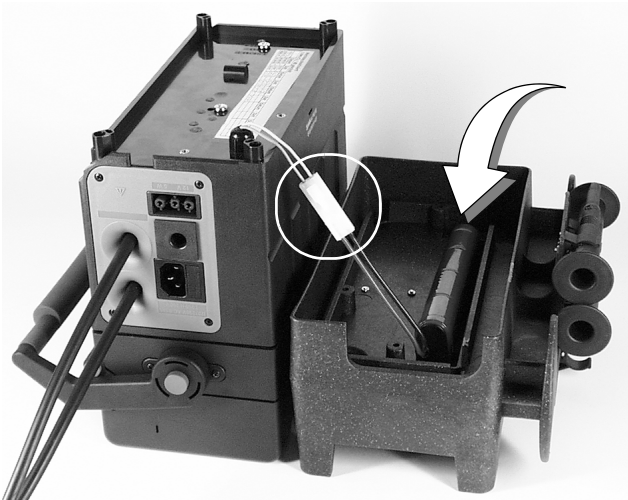

- ⇒ Connect the two cables to each other and secure the connection with the snap hooks.
- ⇒ Position the cable such that it cannot be pinched during subsequent assembly.



- ⇒ Carefully set the device onto the base as shown in the photo by grasping the handle with one hand, and guiding the bottom of the device into position with the other hand.
- ⇒ Grasp the base and the device, and turn the entire unit upside down.

⇒ Secure the base with the included screws and washers.



Attention!

Use only the screws furnished with the device together with washers. Longer screws may reduce creepage distances or damage the device.

If a battery pack (feature C1) has been installed and the device is not connected to the mains, the battery symbol  appears at the display when the device is switched on, and the number of dark bars displayed in the symbol indicates the battery charge level.

After installing the battery pack, the device is automatically supplied with power from the batteries.

3.2 Mains Connection

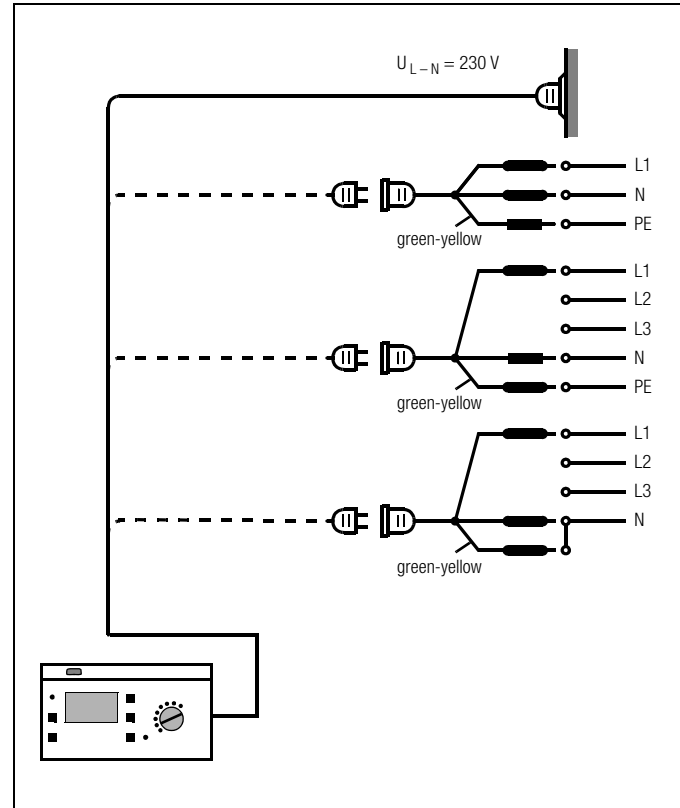



⇒ Connect the test instrument to 230 V or 120 V mains power (depending on the country-specific design) with the included mains connector cable.



Attention!

If a connection via earthing contact outlet is not possible, disconnect the mains from all sources of voltage before connecting the cables of the coupling socket via pick-up clips with the mains connections, as shown in the drawing.

If a battery pack has not been installed, the mains connection symbol  appears after the test instrument has been switched on.

If a battery pack has been installed (feature C1), it is automatically recharged. The battery symbol  appears at the display, and the blinking bars shown in this symbol indicate the remaining capacity which still needs to be charged. The device need not be disconnected from mains power after the batteries have been fully charged (overcharge protection).

3.3 User Interface

Measuring and testing with the METRISO PRIME+ is quick and easy. The integrated user interface provides the operator with information regarding required operating steps, operator errors, measurement results and more for all measuring functions. All information and measurement results appear at a dot matrix LCD panel in plain text.

The integrated user interface is entirely adequate for the great majority of all tests and measurements. Nevertheless, operators should carefully read and understand the contents of these operating instructions.

3.4 Help Functions

Help texts can be queried and displayed at the LCD for all measuring and test functions, and for practically all settings.

Example: Display Contrast Function

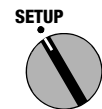

Switch Position



⇒ Press the STORE key in order to query online help:



⇒ Press the same key once again, or the MENU key, in order to exit the help function:



or

⇒ Start the selected function directly from the help menu by pressing the START key:



3.5 Setup

Various basic settings can be selected for the test instrument with the selector switch in the SETUP position.

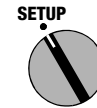

Select Parameter



Open Menu for Entering Parameters



All setting and changes entered to the menu accessed in the SETUP switch position are saved to memory automatically, and are retained after disconnecting the device from mains power.



Exit Function

Restoring default setting – standard values

Switch off the test instrument: switch position OFF. Then press and hold the MENU and i/STORE keys simultaneously, and turn the function key to TEST position. The standard values of the default setting are thus restored.

3.5.1 Adjusting Contrast and LCD Illumination

Contrast can be increased or decreased with this function. LCD illumination can be switched on or off as well.

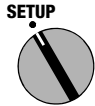

Select Display Contrast



Open Entry Menu



Adjust Contrast



Switch Illumination On or Off *

* Background illumination is switched off automatically after approximately 2.5 minutes if none of the keys are activated during this time. Each time a key is activated, background illumination is extended for an additional 2.5 minutes.

3.5.2 Setting Date and Time

The test instrument's internal clock can be set with this function. The clock continues to run after supply power has been disconnected. Date and time are included in the test reports.

Entries are made using the following formats:

Date: DD.MM.YYYY (Day.Month.Year)
Time: hh:mm (Hour:Minute)



Select Date/Time



Open Entry Menu
(and select date or time)

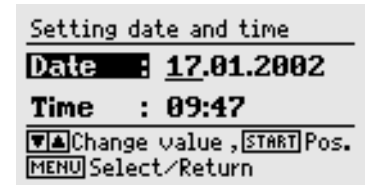

Select Cursor Position



Change Values

3.5.3 Beeper Settings

The beeper can be completely deactivated or activated as indicated in the table below.

	Beeper deactivated	Beeper activated	Beeper for measuring functions	Beeper for high-voltage
Beeper upon key stroke	—	•	—	—
Beeper upon good/bad measurement results *	—	•	•	—
Intermittent beeper for high-voltage > 1000 V	—	•	•	•

* a good measurement result (passed) is indicated with one long acoustic signal, a bad result (failed) with three brief acoustic signals.



Select Beeper



Open Entry Menu



Select Beeper Function

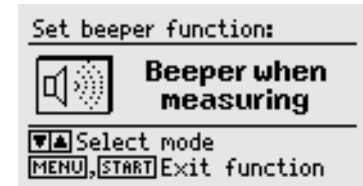

3.5.4 Executing the Self-Test

This function displays important device data first. If required, display lamp and relay functions, as well as other options, can be tested automatically and results appear at the display.



Select Self-Test



Open Entry Menu

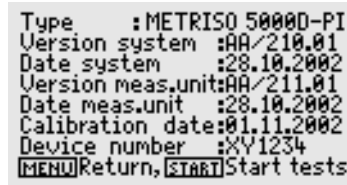

LCD Test

Neighboring horizontal and vertical segments of the LCD panel are activated separately or test images are indicated by means of the following tests. If one of the segments fails to blink, send the test instrument to an authorized service center for repair.

START

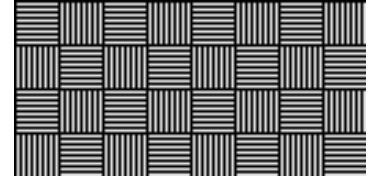

Battery Voltage and LED Test

START



Continue Test

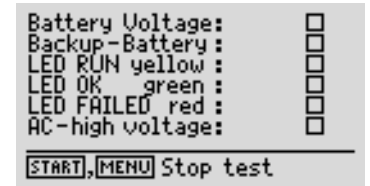

Results: OK



Error message:

- Test failed
- component defective
- component not available (e.g. batteries not inserted or high-voltage module not available)



Note

Before a check mark appears to indicate correct functioning the LEDs must first blink, and the relays must switch.

3.5.5 Organizing Report Data with ETC

ETC is a free starter software program for fast report generation of your measuring results in conjunction with our test instruments. ETC offers a variety of supporting options for data logging, data management as well as report generation.

Downloading the Software ETC

The most up-to-date version of ETC report generating software can be downloaded free of charge from the **mygmc** page of our website as a ZIP file, if you have registered your test instrument:

www.gossenmetrawatt.com

→ Products → Software → Software for Testers

→ Report Software without Database → ETC → [myGMC](#)

4 Performing Tests

Each of the following tests is automatically assigned to one currently available object number. Any given test which is saved to memory with the “STORE” key is stored with reference to this number. The object number can be entered in the “DUT data” menu (see chapter 5.1 on page 34).

Measuring mode operation is always carried out according to the following sequence:

- Select the desired test.
- Enter test parameters (if required).
- Start the measurement or return to the initial menu.
- Save measured values to memory and enter a description (if desired).

Observe the following for all tests:

- Safety features and precautions, see chapter 2.
- Disconnect the device under test from all sources of voltage first.
- Test for absence of voltage.
- Do not disconnect the measurement cables until the device under test has been fully discharged.

4.1 Insulation (resistance) Test

Test voltage can be set between 100 V and 5,000 V for this test. This voltage, as well as the allowable limit value for insulation resistance, can be selected as a test parameter.

Voltage at the device under test appears at the LCD in addition to measured insulation resistance.

Discharge

After the measurement has been completed, the device under test is discharged automatically in order to assure zero voltage. The falling voltage value can be observed at the display during the discharging process. The measured insulation resistance value remains in memory during this period of time.

Interference Voltage

If voltage is present at the test probes after measurement is started, an “**external voltage**” warning appears at the display. The level of the interference voltage is shown at the display. The insulation test is aborted after the test probes have been removed from the DUT. The test has to be conducted again on the de-energized DUT.





Attention!

Do **not** touch the test probes during measurement!
A direct voltage of up to 5000 V is present between the test probes.



Note

Testing the Measurement Cables:

Initial testing should be performed after short-circuiting the measurement cables with their test probes. The instrument should display nearly zero MΩ. A broken measurement cable can be detected in this way.

TEST



Select the Test



MENU

Open the Submenu



4.1.1 Setting Test Parameters

The type of utilized test voltage can be selected here:

- **Fixed test voltage**
- **Variable test voltage**
(e.g. lower test voltage for voltage-sensitive components)
- **Test voltage in a sequence of steps** (U_{STEP} = step voltage), e.g. in order to allow for better evaluation of insulation quality with regard to dielectric strength

Additional parameters must be set as well depending upon the selected type of test voltage.



MENU

Select Parameter

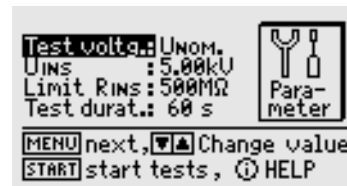

Set Value

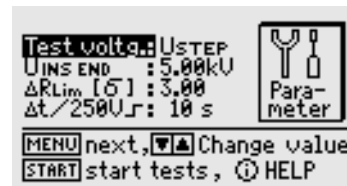

Significance of Parameters with Variable and Fixed Test Voltage

Test voltage U_{nom} : Test voltage in fixed steps
(100/250/500 V, 1.00/1.50/2.00/2.50/5.00 kV)

U_{var} : Variable test voltage
(100 V ... 5.00 kV in 50 V steps)

U_{ins} Test voltage

Limit R_{ins} Limit value for insulation resistance
(If value stays below limit value: measurement failed)

Test duration Maximum test duration in seconds

<Auto>: measurement until steady state is reached
Time in sec.: Measurement = 1 to 120 seconds
>>>>: cont. measurement: stop with MENU key
Time in min log: Measurement = 2 to 60 minutes with automatic storage of 30 measured values at equal time intervals including information on the current test time. (see chapter 4.1.4 on page 24).

Significance of Parameters with Step Voltage

Test v. U_{step} : Test voltage as a sequence of steps

$U_{(INS) END}$ Final value of the step sequence
(250 V ... 5.00 kV in steps of 250 V)

ΔR_{Lim} Maximum allowable statistical deviation from the measured mean value

$\Delta t/250V$ Dwell time per step (10 s ... 50 s)

Resetting parameter values to default setting, see page 16.



Note

In the event of very high insulation resistances the capacitive influence of the person performing the measurement and/or of the measuring cable may distort the measured value.

4.1.2 Starting the Test (U_{NOM} , U_{VAR})

START

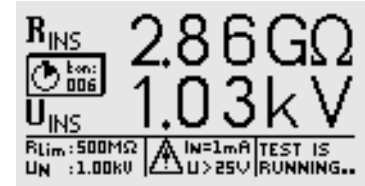

Display of results
after completion of test



4.1.3 Starting the Test (U_{STEP})

START

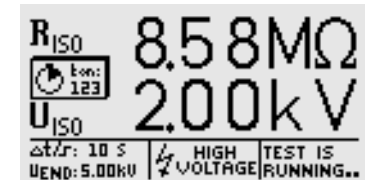



Statistical analysis

U _{INS} [kV]	R _{INS} [Ω]	1.75	0.49M	3.75	0.51M
0.25	0.56M	2.00	0.48M	4.00	0.51M
0.50	0.51M	2.25	0.50M	4.25	0.51M
0.75	0.51M	2.50	0.51M	4.50	0.52M
1.00	0.53M	2.75	0.50M	4.75	0.52M
1.25	0.53M	3.00	0.52M	5.00	0.53M
1.50	0.50M	3.25	0.53M
		3.50	0.51M	ΔR=	0.286

Press the CURSOR DOWN or CURSOR UP keys to return to the previous LCD display.



Note

If the measuring range is exceeded (overflow of display range), no statistical analysis will be performed. In this case, the individual measured values are listed, but no value for ΔR_{MAX} is calculated.



STORE

Press briefly: Save results

Press & hold: Save results and activate the entry field:

A description of the measurement with up to 15 characters can be entered to the information field at the bottom. See chapter 5.1.1 regarding entry.

4.1.4 Data logger function (min log)(as of firmware version AH)



MENU

Select Parameter

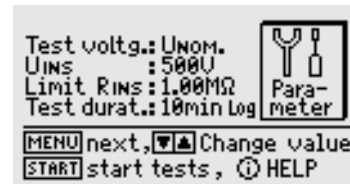

If you choose time parameter setting "min log" from the menu, exactly 30 measured values are automatically stored during the selected test duration at time intervals between 4 seconds and 2 minutes. This makes data logger operation possible for measuring durations between 2 and 60 minutes. In this case, the residual time of the current measurement is not indicated in seconds, but in minutes. While the test is being performed, icon "Stored" is briefly shown in the display and the yellow signal lamp "Testing ..." disappears briefly each time a measured value is being stored. If the signal generator is activated, an acoustic signal sounds additionally.

In this function, the current test time is stored for each measurement instead of the parameter for the test duration to ensure the temporal correlation between measured value and time of measurement.



Note

Before the start of each test with data logger as described in chapter 5.1, select a new device under test to avoid the measured values being stored successively within the same DUT.

This considerably facilitates the subsequent evaluation of the stored measured values.

4.1.5 Measurements with the Guard Cable (feature G1)

The measurement of very high resistances necessitates extremely minimal measuring current and may be rendered problematic as a result of influences such as electromagnetic fields, humidity or surface current. An accurate test set-up is thus absolutely essential.

A guard cable must be used for measurements within a range of $100 \text{ G}\Omega$ ($10 \text{ G}\Omega$) ... $1 \text{ T}\Omega$, in order to prevent surface current from distorting measurement results. The guard rings prevent current at the surface of the insulation material from flowing from the +measurement cable to the -measurement cable, instead of through the insulation material itself.

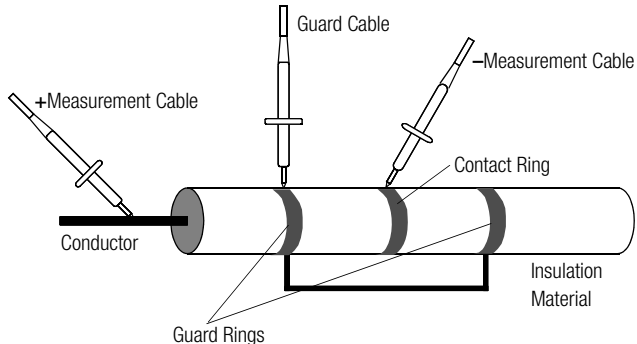

- ⇒ Insert the plug from the guard cable into the appropriate jack in the test instrument.
- ⇒ Plug the alligator clip onto the guard cable test probe.
- ⇒ Connect the alligator clip to the guard ring between the two measuring points at the insulation material under test.
- ⇒ Refer to chapter 4.1.2 on page 23 regarding the measuring sequence



Note

The following materials can be used as guard rings: aluminum foil, copper foil or metallic hose clamps.

4.2 Polarization Index Measurement

A polarization index test is recommended for electrical machines. This procedure involves expanded testing of insulation resistance. DC measuring voltage from the METRISO PRIME+ is applied to the insulation for a duration of 10 minutes. Measured values are documented after one minute, and after ten minutes. If the insulation is good, the value measured after ten minutes is higher than the value measured after one minute. The relationship between the two measurement values is the polarization index. Charged material within the insulation is aligned due to the application of measuring voltage over a long period of time, resulting in polarization. The polarization index indicates whether or not the charged material contained in the insulation can still be moved, thus allowing for polarization. This, in turn, is an indication of the condition of the insulation.

The following rules apply in general:

- PI values < 1** Troubleshooting is required.
- PI values = 1 ... 2** Maintenance is recommended.
- PI values = 2 ... 4** DUT is OK, no immediate action is required. Preventive maintenance can be planned according to the number of tests to be performed.
- PI values > 4** DUT is in flawless condition.

Applications

Determination of moisture and contamination levels

Absorption Index (DAR) – DC Charging Test

The absorption index test is part of the polarization index test. Insulation resistance measurements are placed in relationship to one another after 30 and 60 seconds.

Application: Faster version of the polarization index test



Select the Test



Open the Submenu



4.2.1 Setting Test Parameters

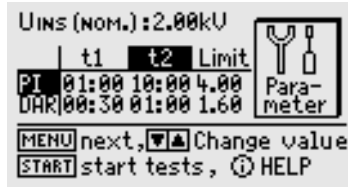

Significance of Parameters

- $U_{ins[nom]}$** Nominal insulation voltage
100/250/500 V, 1.00/1.50/2.00/2.50/5.00 kV
- PI(t2/t1)** Polarization index PI is the relationship between insulation resistance values measured after 1 minute PI(t1), and after 10 minutes PI(t2). Other durations can be selected if required.
- PI (limit)** Selected polarization index limit value: appears in the footer in the measuring menu
- DAR(t2/t1)** Absorption ratio DAR is the relationship between insulation resistance values measured after 30 seconds DAR(t1), and after 60 seconds DAR(t2). Other durations can be selected if required.
- DAR (limit)** Selected absorption ratio limit value: appears in the footer in the measuring menu

For resetting parameter values to default setting, see page 16.

4.2.2 Starting the Test

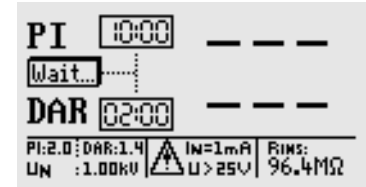

The two countdown timers (10:00 and 02:00) display remaining test time for each respective function.



- Press briefly:** Save results
- Press & hold:** Save results and activate the entry field:
A description of the measurement with up to 15 characters can be entered to the information field at the bottom. See chapter 5.1.1 regarding entry.

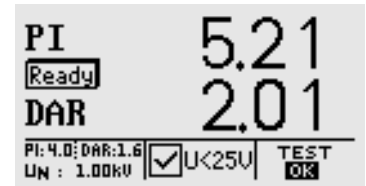

4.3 Breakdown Voltage

Step-Voltage Test – DC Charging Test

Voltage is increased up to the limit value (selected maximum test voltage) over the selected rise time during the breakdown voltage test. If voltage breakdown occurs before this value is reached, breakdown voltage U_{brk} is displayed.

If the selected test voltage is reached, testing is continued at this voltage level until the time period selected under “test duration” has elapsed.

If no breakdown occurs before the selected test duration has elapsed, the test has been passed, in which case the following display appears: $U_{brk} ---$. Breakdown voltage is displayed in all other cases.

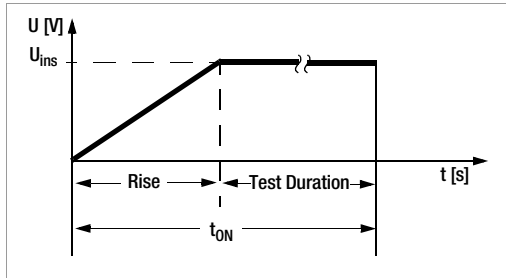

Applications

For the recognition of cracks and holes in the insulation



Select the Test



Open the Submenu



4.3.1 Setting Test Parameters



Set Parameters

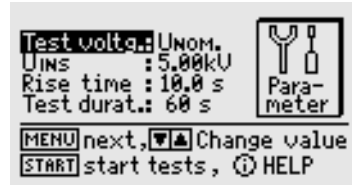

Significance of Parameters with Variable and Fixed Test Voltage

- Test voltage** U_{nom} : Test voltage in fixed steps (100/250/500 V, 1.00/1.50/2.00/2.50/5.00 kV)
 U_{var} : Variable test voltage (100 V ... 5.00 kV)
- U_{ins}** Test voltage (see fixed steps above)
- Rise** Time after which maximum test voltage will be reached (5 s ... 300 s)
- Test duration** Test duration at maximum test voltage (AUTO, 1 s ... 120 s, >>>> (continuous, burn mode))

For resetting parameter values to default setting, see page 16.

4.3.2 Starting the Test

START



STORE

- Press briefly:** Save results
- Press & hold:** Save results and activate the entry field:
A description of the measurement with up to 15 characters can be entered to the information field at the bottom. See chapter 5.1.1 regarding entry.

4.4 Capacitance Measurement and Determination of Dielectric Discharge (optional)

Capacitance measurement is performed with adjustable test voltage by charging with constant current. The measurement is performed with automatic range selection. One of the nominal test voltages (U_{nom}), or a freely selectable test voltage (U_{var}) can be used.

Dielectric Discharge Test (DD)

This test was developed for use with large machines and is performed, as its name indicates, during discharge. It designates the ratio of the discharge current after one minute and the product of voltage by capacitance:

$$DD = \frac{I_{Disch}(1\text{ min})}{U \cdot C} \cdot 1000$$

DD values > 4: Troubleshooting is required

DD values = 2 ... 4 Maintenance is recommended

DD values < 2 DUT is OK, no immediate action is required.

Application: Determination of the magnitude of absorbed contamination or moisture



Select the Test



Open the Submenu



4.4.1 Setting Test Parameters



Set Parameters

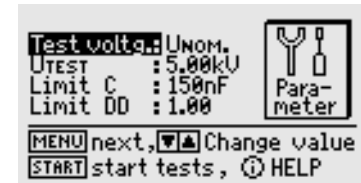

For resetting parameter values to default setting, see page 16.

4.4.2 Starting the Test

START



After capacitance has been determined, the instrument automatically continues with dielectric discharge testing. This takes about 30 minutes. However, the measurement can be aborted at any time by pressing the MENU key. Only capacitance is displayed in this case.

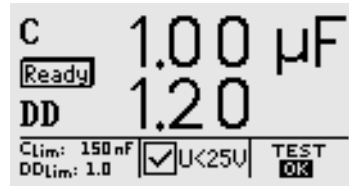

STORE

Press briefly: Save results

Press & hold: Save results and activate the entry field:

A description of the measurement with up to 15 characters can be entered to the information field at the bottom. See chapter 5.1.1 regarding entry.

4.5 Voltage Measurement (protection against residual voltage)

EN 60204 requires that voltages in excess of 60 V occurring at all accessible machine components during operation must drop to a residual voltage value of 60 V or less within a period of 5 seconds after supply power has been switched off.

Testing for the absence of voltage is performed by means of a voltage measurement which involves measuring discharge time with the METRISO PRIME+. Elapsed time as of disconnection from supply power is displayed continuously at the LCD during discharge, until the limit value of 60 is reached.

In addition to voltage type (AC, DC or AC+DC), frequency is measured and displayed as well. The mean value is always read out.

In addition to voltage and frequency, voltage type (AC, DC or AC+DC) appears at the symbol field in the display.

If voltage drops by more than 5% of the measured value during a single measuring period (approx. 0.7 sec.) while performing a voltage measurement which results in a value of greater than 60 V, a time measurement is started automatically in order to test protection against residual voltage. This time measurement can be observed at the display in the symbol field. Time measurement is stopped after voltage drops to below the limit value of 60 V. Time required to discharge down to 60 V then appears at the display in seconds. Voltage measurement continues until maximum allowable discharge time has elapsed (normally 5 seconds). The results of the voltage measurement are then “frozen”, and the DATA HOLD symbol appears at the display. If the 60 V limit value is not reached before allowable discharge time has elapsed, the voltage value is “frozen” and time measurement continues until the 10 second time limit has elapsed. If voltage is still greater than 60 V after 10 seconds, the test is aborted and the instrument restarts voltage measurement.

When the display is “frozen”, voltage measurement is not started again until:

- The START key is pressed.
- The measured value is saved to memory by pressing the i/Store key.
- Voltage measurement is restarted from the menu.
- Or voltage at the test probes climbs back up to a value of greater than 60 V, or if the next measured value after a measurement of greater than 60 V is even higher, i.e. if a climbing tendency can be observed.

Both elapsed time and the prevailing voltage value after allowable discharge time has elapsed are saved to memory by pressing the i/Store key. If no discharge takes place, only the voltage value is saved.



Note

If, for example, conductors are exposed when a machine is switched off – e.g. if plug connectors are disengaged – and if these are not protected against direct contact, maximum allowable discharge time is 1 second!



TEST



Select the Test



MENU

Open the Submenu



4.5.1 Setting Test Parameters

The **discharge** time during which the voltage value must drop to a non-hazardous value of less than 60 V can be specified as a **limit value** between 1.0 and 9.00 seconds. The following message appears in order to indicate that the limit has been reached: “residual voltage less than 60 V!”.



Set Discharge Time

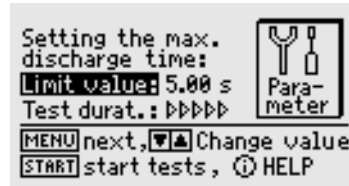

Test duration is always set to continuous measurement in this case because residual voltage testing is triggered automatically and voltage measurement is always active for safety reasons.

For resetting parameter values to default setting, see page 16.

4.5.2 Starting the Test

START

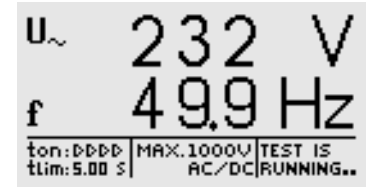

STORE

Press briefly: Save results

Press & hold: Save results and activate the entry field:

A description of the measurement with up to 15 characters can be entered to the information field at the bottom. See chapter 5.1.1 regarding entry.

5 Processing, Reorganizing and Deleting Data

Previously stored data and data records can be processed with the selector switch in the **data management** position.

The following functions are available:

- **DUT data**
An object number can be assigned here, and measurements can be saved with reference to the selected number. Beyond this, a description can be entered for the respective object.
- **Data Processing**
Individual data resulting from a measurement (e.g. insulation measurement) performed on a previously selected object can be displayed with this function, and subsequently deleted if desired.
- **Data Reorganization**
Previously entered objects can be deleted from memory with this function, and memory can be tested as well.
- **Clear Memory**
This command deletes data records previously saved to memory for all objects. Full memory capacity is made available by means of this procedure.

Memory Occupancy

Current memory occupancy is continuously displayed as a bar graph for the first three menu items listed above.

Depending upon the number of objects stored to memory (max. 254), up to 1,600 measurements can be saved.

5.1 Select Device under Test (DUT)

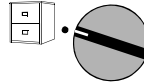

Select a Command



Submenu

Object no.



Select Number

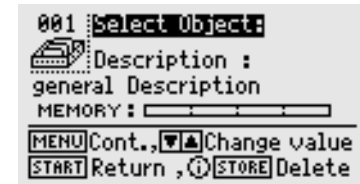

Status: A filled file cabinet indicates that measurement data have already been saved to memory for the selected object.

5.1.1 Entering Descriptions

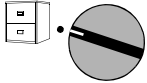

Description

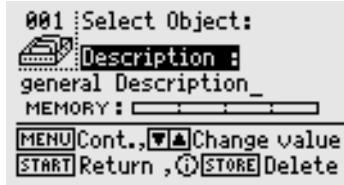

Description: A description can be entered here for an object, which is displayed and subsequently printed out when the respective object is selected.

There are five different ways to enter descriptions:

- Convenient entry with the PSI module (feature I1)
In this case, descriptions are entered using the alphanumeric keypad included with the PSI module (see operating instructions for SECUTEST PSI).
- Entry with the help of a barcode scanner (accessory no. B3261) or RFID scanner (accessory no. Z751G)
- Entry from a terminal
- Entry with PC keyboard via the PROFI-MFII adapter (accessory no. Z504H)

- Entry using keys at the METRISO PRIME+



Select Letter, Number or Character.



Move Cursor Left



Move Cursor Right



Completed entries must be acknowledged with the MENU key. The entry is then saved to memory. Alternatively, the "Store" key can be pressed at the PSI module.

Up to 250 characters can be entered. The entry line scrolls automatically.

A comment can be entered for each test step in the same way, immediately after the test has been performed. However, the length of these comments is limited to 15 characters.

5.1.2 Copying Descriptions

⇒ Select the object with the description to be copied and press the MENU key 3 times.

⇒ Select the new object and press the MENU key.

The copied text is displayed and can be edited.

5.1.3 Deleting Descriptions

⇒ Simultaneously press the i/STORE and START keys.

The description is deleted and the cursor is sent to the first character entry position in the description field.

5.2 Processing Data (checking measured values)

Measured values can be checked with this function, and individual measurements can be deleted if desired.

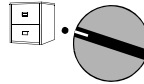

Select a Command



Select an Object



Delete the Object

“Data record deleted” appears after deletion of the respective measurement has been started.

In order to delete a data record, the i/Store key must be pressed and held for approximately 1 second, thus avoiding inadvertent deletion. If the key is not released, all subsequent data records are then deleted sequentially at a rate of 1 record per second.

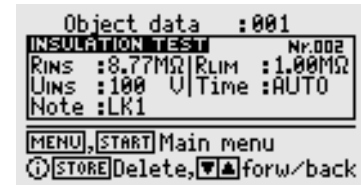

5.3 Data Reorganization

5.3.1 Deleting Already Printed Data

Data for individual DUTs which have already been printed out in report form, or DUTs which have been entered although no measured values have been saved for them yet, can be deleted here if desired.

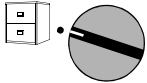

Select a Command



Submenu



Start Deletion



Delete the Object

Security acknowledgement must be entered before deleting each individual object. As soon as objects whose data have already been printed out in report form have been deleted, a message to this effect appears. If the START key is pressed once again, a

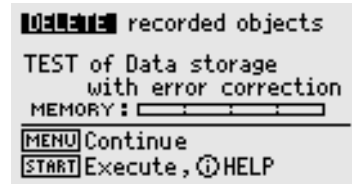

print-out is generated including all DUTs for which measured data are stored to memory.

5.3.2 Memory Test

The memory module is checked for errors with this function. Errors can be corrected in some cases. Follow the instructions which appear at the display.



START



Test Memory (press 3 times)

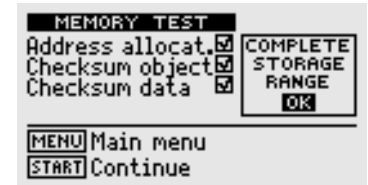

5.4 Clearing the Memory

This command deletes data records previously saved to memory for all DUTs. Full memory capacity is made available by means of this procedure.



Attention!

Data should be downloaded to a PC and saved before clearing the memory!

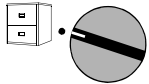

Select a Command



Submenu

START



Execute the Command

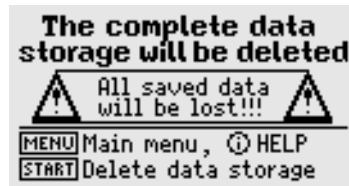

A security acknowledgement must be entered before memory is cleared. Final deletion is initialized with the **iSTORE** key.



Clearing the memory entirely may take several seconds. “Memory cleared” is then displayed.

6 Printing Test Results

The test instrument's report functions can be activated with the selector switch in the **printer** position. The following functions are available:

Print out values at the PSI module (feature I1):

Measured values for a selected object can be printed out at the utilized printer module via the serial interface.

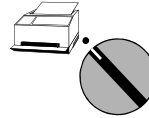

Select Printer



Printer Menu



Select an Object or a Number



Start Printing *

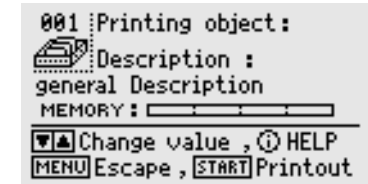

Status: A filled file cabinet indicates that measurement data have already been saved to memory for the selected DUT.

A printer symbol appears as long as data is being transmitted to the printer.

* A print-out which has already been started can only be aborted by turning the selector switch. An error message is generated if the printer does not work. Printing must be restarted in this case.

7 Characteristic Values

Standards	DIN EN 61557-1:2007 DIN EN 61557-2:2008
VDE regulations	VDE 0413-1:2007 VDE 0413-2:2008

Insulation Resistance

Display Range [Ω]	Measuring Range [Ω]	Test Voltage	Intrinsic Uncertainty	Measuring Uncertainty
0.00 M ... 50.0 G	0.60 M ... 10.0 G	100 V ... 250 V	±(7% rdg. + 6 d)	±(10% rdg. + 8 d)
	> 10.0 G ... 50.0 G		±(7% rdg. + 6 d)	±(10% rdg. + 8 d)
0.00 M ... 250 G	0.40 M ... 50.0 G	> 250 V ... 1.00 kV	±(7% rdg. + 6 d)	±(10% rdg. + 8 d)
	> 50.0 G ... 250 G		±(7% rdg. + 6 d)	±(10% rdg. + 8 d)
0.00 M ... 999 G	0.40 M ... 200 G	> 1.00 kV ... 5.00 kV	±(7% rdg. + 6 d)	±(10% rdg. + 8 d)
	> 200 G ... 999 G		±(7% rdg. + 6 d)	±(10% rdg. + 8 d)

Test duration: automatic (until measured value stabilizes),
manual (1 ... 120 s) or continuous measurement (lock function)

Polarization Index (PI), Absorption Ratio (DAR)

	t1	t2	Limit
PI	00:00 ... 01:00 ... 99:50 min	00:00 ... 10:00 ... 99:50 min	0.10 ... 4.00 ... 9.80 min
DAR	00:00 ... 00:30 ... 99:50 min	00:00 ... 01:00 ... 99:50 min	0.10 ... 1.60 ... 9.80 min

PI and DAR are calculated values. Insulation measurement specifications apply.

Insulation Test Voltage

Nominal Values, Test Voltage	Variable Test Voltage	Nominal Current	Intrinsic Uncertainty
100 V, 250 V, 500 V, 1.00 kV		≥ 1.0 mA	0 ... +25% rdg.
1.50 kV, 2.00 kV, 2.50 kV		≥ 0.4 mA	± 5% rdg.
5.00 kV		≥ 0.1 mA	± 3.5% rdg.
	100 V...1.00 kV	≥ 1.0 mA	± 15% rdg.
	> 1.00 kV...2.50 kV	≥ 0.4 mA	± 5% rdg.
	> 2.50 kV...5.00 kV	≥ 0.1 mA	± 3.5% rdg.

Variable test voltage selectable in 50 V steps
Short-circuit current less than 2 mA with test voltage to 1.00 kV

Voltage Measurement

Measuring Range	Frequency in Hz	Impedance	Intrinsic Uncertainty	Measuring Uncertainty
dc test voltage 50 V ... 5.00 kV	—	—	±(2.5% rdg. + 5 d)	±(5% rdg. + 5 d)
50 V ... 1.00 kV ac/dc	15 ... 500	1 MΩ	±(2.5% rdg. + 2 d)	±(5% rdg. + 5 d)
50 V ... 1.00 kV ac/dc	> 500 ... 1 k	1 MΩ	±(10% rdg. + 2 d)	±(12.5% rdg. + 5 d)

Frequency Measurement

Measuring Range	Impedance	Intrinsic Uncertainty	Measuring Uncertainty
15.0 Hz ... 1.00 kHz	1 MΩ	±(0.5% rdg. + 2 d)	±(1% rdg. + 2 d)

Measured quantity voltage: 50 V ... 1 kV

Breakdown Voltage

Parameter	Setting Range	Intrinsic Uncertainty	Measuring Uncertainty
Voltage range	100 ... 5,000 V	±(10% rdg. + 8 d)	±(15% rdg. + 10 d)
Rise time	5 ... 300 s	—	—
Measuring time	1 ... 120 s / auto / continuous measurement	—	—

Capacitance Measurement

Display Range	Measuring Range	Test Voltage	Intrinsic Uncertainty	Measuring Uncertainty
0.00 ... 10.0 μ F	0.10 ... 5.00 μ F	100...450 V 500...5 kV	$\pm(10\% \text{ rdg.} + 5 \text{ d})$ $\pm(5\% \text{ rdg.} + 5 \text{ d})$	$\pm(15\% \text{ rdg.} + 8 \text{ d})$ $\pm(10\% \text{ rdg.} + 8 \text{ d})$

Dielectric Discharge (DD)

	Limit
DD	0.10 ... 2.00 ... 9.80

Reference Conditions

Ambient temperature	+23 °C \pm 2 K
Relative humidity	40 ... 60 %
Measured quantity frequency	50 Hz \pm 10 Hz (during voltage measurement)
Line voltage waveshape	Sinusoidal, deviation between RMS and rectified value < 1 %

Power Supply

Line voltage	207 V ... 253 V / 49 Hz ... 61 Hz or (depending on country-specific design) 108 V ... 132 V / 59 Hz ... 61 Hz
Power consumption	< 18 VA
Set of batteries	NiMH 9.6 V, 3 Ah, charging time 6 hours
Number of measurements with nominal current per VDE 0413	700

Electrical Safety

Standards	IEC 61010-1:2001 DIN EN 61010-1:2011
VDE regulations	VDE 0411-1:2011
Pollution degree	2
Protection	IP 40
Measuring category	Insulation measurement – 5000 V DC – no overvoltage Voltage measurement – 1000 V CAT II, 600 V CAT III, 300 V CAT IV
Safety class	II

Electromagnetic Compatibility (EMC) METRISO PRIME+

Product standards EN 61326-1:2013

Interference Emission	
EN 55022	Class A
Interference Immunity	Test Value
EN 61000-4-2	Contact/atmos. – 4 kV/8 kV
EN 61000-4-3	10 V/m
EN 61000-4-4	Mains connection – 2 kV
EN 61000-4-5	Mains connection – 1 kV
EN 61000-4-6	Mains connection – 3 V
EN 61000-4-11	0.5 period / 100%

Warning!

This is a class A device. This device may cause radio interference in residential areas.

If this is the case, the owner may be required to implement appropriate corrective measures.

Mechanical Design

Display

Multiple display with dot matrix
128 x 64 pixels

Dimensions

W x H x D:
255 mm x 133 mm x 240 mm

Weight

approx. 5 kg with batteries

Ambient Conditions

Accuracy 0 °C ... + 40 °C

Operating temperature –5 °C ... + 40 °C

Storage temperature –20 °C ... + 60 °C (without battery set)

Relative humidity max. 75%, no condensation allowed

Elevation to 2000 m

8 Data Interfaces

8.1 RS 232 Serial Interface

The data interface socket connector (4) is used to connect the SECUTEST PSI module (feature I1).

Pins 9 and 6 may not be short jumpered to pin 5!

8.1.1 Software Analysis of Measurement Results

Test reports can be conveniently created at a PC and downloaded to the test instrument with the included software.

8.1.2 Interface Specification and Protocol

The interface included with the METRISO PRIME+ complies with the RS 232 standard.

Technical Data:

Baud rate 9600 baud, fixed

Character length 8 bit







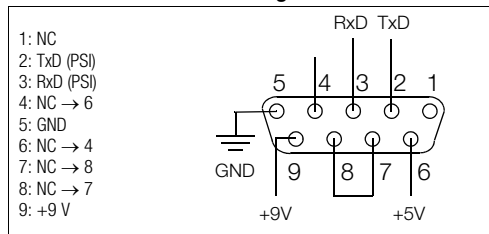



Parity none





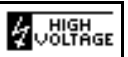
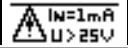





Stop bits 1

8.1.3 Connector Pin Assignments

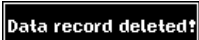

9 Displays and Error Messages – Causes – Remedies

Displays and Error Messages	Meaning / Cause	Remedy
Test Sequence		
	Countdown runs here until residual voltage is less than 60 V.	
	All-clear after an insulation test: voltage at test probes less than 25 or 60 V depending upon measuring function	
	The test has been passed.	
	The test results are not within allowable limit values.	
LCD does not light up	<ul style="list-style-type: none"> – Mains cable not plugged in – Mains fuse is blown 	<ul style="list-style-type: none"> – Plug in the mains cable (see chapter 3.2 on page 14). – Replace the mains fuse (see chapter 10.1 on page 46).
	Indicates type of voltage: Alternating voltage with superimposed direct voltage – direct voltage – alternating voltage	
	Insulation measurement: Interference voltage at the test probes, measurement aborted	
	Warning against high voltage, voltage at the test probe between 1,000 V and 5,000 V	
	Warning concerning a source of danger, voltage at the test probe between 25 V and 1,000 V	
	This symbol appears after the voltage measurement value has been frozen (see chapter 4.5 on page 32).	
Database Operations		
	<ul style="list-style-type: none"> – No measurement has been performed. – The measurement has already been saved to memory. 	
	See text at the display.	Press the START key to repair.
 Recommendat.: clear Memory	An error has occurred while saving data to memory.	Save data to a PC and then clear the memory.

Displays and Error Messages	Meaning / Cause	Remedy
	See text at the display.	Press the START key to repair.
	Memory is no longer able to save new measurement data.	Save data to a PC and then clear the memory.
 Data storage full!!! New objects cannot be entered anymore.	See text at the display.	Transmit data to a PC or print them out, and then delete DUTs which are no longer necessary, or clear the entire memory.
	No data have yet been saved to this data record.	
	Printing is not possible.	Check connections at the printer and make sure paper is available. Check the printer for possible errors.
	Data are being transferred to the printer. The printer may wait until data transmission has been entirely completed before it starts printing.	
	A filled file cabinet indicates that measurement data have already been saved to memory for the selected DUT.	
	The data record has been deleted for a DUT.	
 No usable data in memory!!!!	The printer is not working.	Check the data record.
 Printout Error!!! Check connection → 	The printer is not working.	Check the connection between the printer and the METRISO PRIME+. Then press the START key.
Busy printing data... Abort by turning switch.	The printer is working correctly.	Turn the selector switch in order to abort the print-out.
	The measurement has been saved to memory.	

10 Maintenance

10.1 Replacing the Mains Fuse



Attention!

Disconnect the device from the measuring circuit at all poles before opening the fuse compartment!
Disconnect the device from the mains.



Attention!

Use only **specified, original replacement fuses!**
Bypassing or repairing fuses is prohibited!
If **fuses** with other current ratings, breaking capacities or blowing characteristics are used, the device may be damaged!

- ⇒ Open the fuse compartment at the inlet socket with a suitable tool (e.g. a screwdriver).
- ⇒ Replace the blown fuse with a new fuse with identical specifications.
- ⇒ Close the fuse compartment.

10.2 Testing of Rechargeable Batteries

Check the batteries for leakage or damage at short regular intervals, and after long periods of storage. If damage or leakage has occurred, carefully and completely clean the electrolyte from the instrument with a damp cloth, and replace the batteries with a new battery pack (accessory no.) before placing the instrument back into service.

If the battery test (see chapter 3.5.4 on page 19) indicates that backup battery voltage or rechargeable battery voltage has dropped below the minimum allowable value, recharge the battery pack or have the backup battery replaced by GMC-I Service GmbH.



Note

Prior to lengthy periods of rest (e. g. holiday), we recommend removing the (rechargeable) batteries. This helps to prevent excessive depletion or leakage of batteries, which, under unfavourable circumstances, may cause damage to the instrument.

10.3 Housing and Test Probes

No special maintenance is required. Keep outside surfaces clean **and dry**. Use a slightly dampened cloth for cleaning. Avoid the use of solvents, cleansers and abrasives.



Attention!

No **condensation** may be permitted to occur at the test instrument, the test cables or the device under test, because high-voltage may otherwise cause leakage current at the surfaces. Insulated components may also conduct high-voltage in this case.

Measurements may not be performed under moist ambient conditions, where condensation has occurred or in explosive atmospheres.

10.4 Measurement Cables

Inspect the measurement cables for mechanical damage at regular intervals.



Attention!

Even if only minimal damage is discovered at the test cables, it is advisable to send them immediately to GMC-I Service GmbH.

10.5 Recalibration

The respective measuring task and the stress to which your measuring instrument is subjected affect the ageing of the components and may result in deviations from the guaranteed accuracy. If high measuring accuracy is required and the instrument is frequently used in field applications, combined with transport stress and great temperature fluctuations, we recommend a relatively short calibration interval of 1 year. If your measuring instrument is mainly used in the laboratory and indoors without being exposed to any major climatic or mechanical stress, a calibration interval of 2-3 years is usually sufficient.

During recalibration* in an accredited calibration laboratory (DIN EN ISO/IEC 17025) the deviations of your instrument in relation to traceable standards are measured and documented. The deviations determined in the process are used for correction of the readings during subsequent application.

We are pleased to perform DAkkS or factory calibrations for you in our calibration laboratory. Please visit our website at www.gossenmetrawatt.com (→ Company → DAkkS Calibration Center or → FAQs → Calibration questions and answers).

By having your measuring instrument calibrated regularly, you fulfill the requirements of a quality management system per DIN EN ISO 9001.

* Verification of specifications or adjustment services are not part of the calibration. For products from our factory, however, any necessary adjustment is frequently performed and the observance of the relevant specification is confirmed.

10.6 Device Return and Environmentally Compatible Disposal

The instrument is a category 9 product (monitoring and control instrument) in accordance with ElektroG (German Electrical and Electronic Device Law). This device is subject to the WEEE directive. Furthermore, we make reference to the fact that the current status in this regard can be accessed on the Internet at www.gossenmetrawatt.com by entering the search term WEEE.

We identify our electrical and electronic devices in accordance with WEEE 2012/19/EU and ElektroG with the symbol shown to the right per DIN EN 50419.



These devices may not be disposed of with the trash. Please contact our service department regarding the return of old devices.

If you use **batteries** or **rechargeable batteries** in your instrument or accessories which no longer function properly, they must be duly disposed of in compliance with the applicable national regulations.

Batteries or rechargeable batteries may contain harmful substances or heavy metal such as lead (Pb), cadmium (Cd) or mercury (Hg).

They symbol shown to the right indicates that batteries or rechargeable batteries may not be disposed of with the trash, but must be delivered to collection points specially provided for this purpose.



Pb Cd Hg

11 Appendix

11.1 Glossary

Abbreviation	Meaning
DAR	Absorption Ratio: Ratio between insulation resistance values measured after 30 and 60 seconds
DD	Dielectric Discharge
ΔR_{Lim}	Maximum allowable statistical deviation from the measured mean value
$\Delta t/250V$	Dwell Time per Step
PI	Polarization Index: Ratio between insulation resistance values measured after 1 and 10 minutes
I_{MAX}	Max. allowable current before high-voltage is switched off
I_T	Interrupting current for high-voltage test
R_{ins}	Insulation Resistance
Limit R_{ins}	Limit value for insulation resistance
T_R	Rise time: time during which test voltage climbs to $U_{AC,MAX}$.
T_D	Test duration at maximum test voltage $U_{AC,MAX}$. (not including rise time T_R)
$U_{AC,MAX}$	Maximum test voltage for high-voltage testing
U_{brk}	Breakdown Voltage
U_{ins}	Test Voltage
$U_{(ins) end}$	Ramp Function Upper Limit
U_{meas}	Measuring Voltage
U_{nom}	Nominal Test Voltage
U_T	Voltage value before exceeding interrupting current during high-voltage testing
U_{STEP}	Test voltage as ramp sequence
U_{test}	Test Voltage
U_{var}	Variable Test Voltage

11.2 Minimum Display Values in Consideration of Measuring Error

Table for determining minimal display values for insulation resistance in consideration of the instrument's measuring error:

Limit Value	Minimum Display Value		Limit Value	Minimum Display Value
0.10 M Ω	0.12 M Ω		100 M Ω	118 M Ω
0.20 M Ω	0.23 M Ω		200 M Ω	228 M Ω
0.50 M Ω	0.56 M Ω		500 M Ω	558 M Ω
1.00 M Ω	1.18 M Ω		1.00 G Ω	1.18 G Ω
2.00 M Ω	2.28 M Ω		2.00 G Ω	2.28 G Ω
5.00 M Ω	5.58 M Ω		5.00 G Ω	5.58 G Ω
10.0 M Ω	11.8 M Ω		10.0 G Ω	11.8 G Ω
20.0 M Ω	22.8 M Ω			
50.0 M Ω	55.8 M Ω			

11.3 Voltage at Device Under Test During Insulation Resistance Test

Test voltage U at the device under test depending upon its resistance R_x at nominal voltage 100, 500, 1000, 2400 and 5000 V:

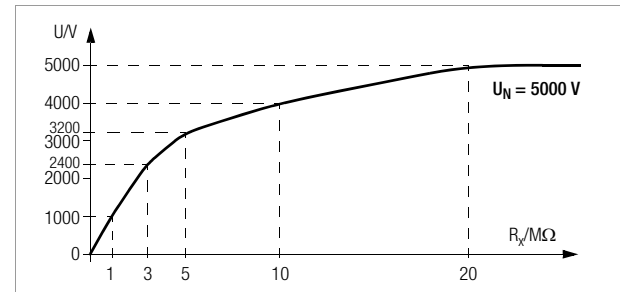
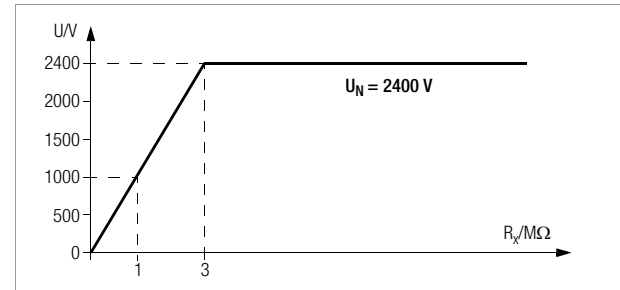
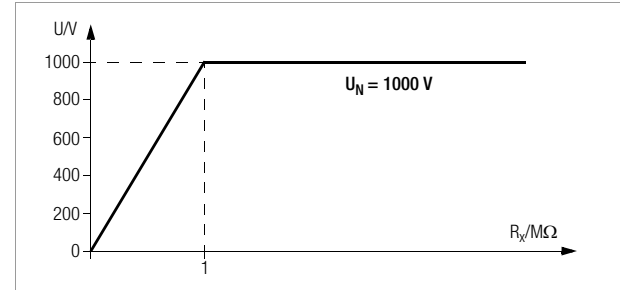
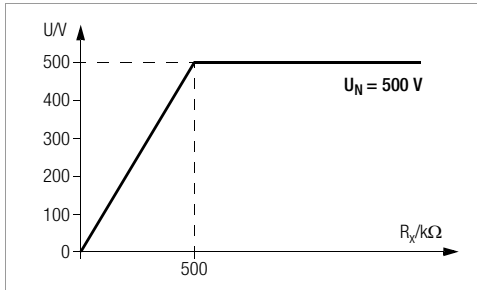
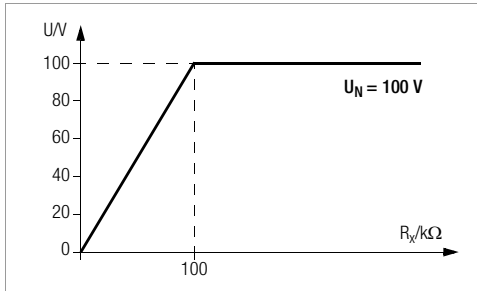

11.4 Index

B	
Beeper	
Setting	18
D	
Data management	
Data	
Deleting	39
Processing	38
Description	
Copying	38
Deleting	38
Entry	37
Entry options	37
Display messages	46
Memory	
Deleting	40
Occupancy	36
Testing	39
Printing test results	41
Selecting device under test	36
Discharge	
Automatic after insulation test	23
Dielectric during capacitance measurement	32
E	
ETC	
Transmission and print-out of report data	22
F	
Fuses	
Replacement	48
I	
Interference voltage	
during insulation test	23
M	
Measuring of	
Absorption index	28
Breakdown voltage	30
Capacitance	32
High resistances	27
Polarization index	28
Voltage	34
P	
Product Support Hotline	55
R	
Residual voltage	
Determining the value	34
Display of discharge time	34
S	
Safety measures	
Control circuits	10
Frequency Converters	10
Neutral conductor	10
PELV circuits	10
Persons	10
TN systems	10

Statistical analysis	
during insulation measurement	26
Storage batteries	
Display of measuring voltage	19
Display of remaining capacity	15
Operation with battery pack	12
Recharging during mains operation	15
T	
Test voltage	
during HV test	
on device under test	52
during insulation test	
Fixed steps	25
on device under test	52
variable/50 V steps	25
during insulation test as a sequence of steps	25
W	
WinProfi	
Installation and program start	20

12 Repair and Replacement Parts Service, Calibration Center* and Rental Instrument Service

When you need service, please contact:

GMC-I Service GmbH
Service Center
Beuthener Straße 41
90471 Nürnberg, Germany
Phone: +49 911 817718-0
Fax: +49 911 817718-253
e-mail: service@gossenmetrawatt.com
www.gmci-service.com

This address is only valid in Germany.
Please contact our representatives or subsidiaries for service in other countries.

*** DAkkS Calibration Laboratory for Measured Electrical Quantities:
D-K-15080-01-01 accredited as per DIN EN ISO/IEC 17025**

Accredited quantities: direct voltage, direct current value, direct current resistance, alternating voltage, alternating current value, alternating current active power, alternating current apparent power, DC power, capacitance, frequency and temperature

Competent Partner

Gossen Metrawatt GmbH is certified in accordance with DIN EN ISO 9001.

Our DAkkS calibration laboratory is accredited by the Deutsche Akkreditierungsstelle GmbH (National accreditation body for the Federal Republic of Germany) in accordance with DIN EN ISO/IEC 17025 under registration number D-K-15080-01-01.

We offer a complete range of expertise in the field of metrology: from **test reports** and **proprietary calibration certificates** right on up to **DAkkS calibration certificates**.

Our spectrum of offerings is rounded out with free **test equipment management**.

An **on-site DAkkS calibration station** is an integral part of our service department. If errors are discovered during calibration, our specialized personnel are capable of completing repairs using original replacement parts.

As a full service calibration laboratory, we can calibrate instruments from other manufacturers as well.

13 Product Support

When you need service, please contact:

Gossen Metrawatt GmbH

Product Support Hotline

Phone: +49 911 8602-0

Fax: +49 911 8602-709

e-mail support@gossenmetrawatt.com

© Gossen Metrawatt GmbH

Prepared in Germany • Subject to change without notice / Errors excepted • A PDF version is available on the Internet

All trademarks, registered trademarks, logos, product names, and company names are the property of their respective owners.



Gossen Metrawatt GmbH
Südwestpark 15
90449 Nürnberg • Germany

Phone +49 911 8602-0
Fax +49 911 8602-669
E-Mail info@gossenmetrawatt.com
www.gossenmetrawatt.com